

Challenge

Background

Rubber lip seals used on high-speed offset printers were wearing prematurely, resulting in oil leakage and causing excessive maintenance. On average, seals lasted one year or less.

Offset printers use plates to transfer an image onto a “rubber” blanket which is subsequently rolled onto a sheet of paper. Once setup, these printers run with high efficiency for high volume document production.

This requires seals that can withstand high speeds, pressure, and vibration.



Offset printing press.

Solution

Product

A Chesterton® 100 Series (115) Cantilever Spring-Energized Seal was installed in the vibrator drive units of the offset printing presses. Jackets were made of polyimide-filled PTFE used for its low friction and excellent wear characteristics. The cantilever spring was fabricated from 300 series stainless steel. An FKM O-Ring was installed on the static side and an aluminum shell formed over the outer surface. Each seal assembly was press-fit into place for final installation in the equipment.

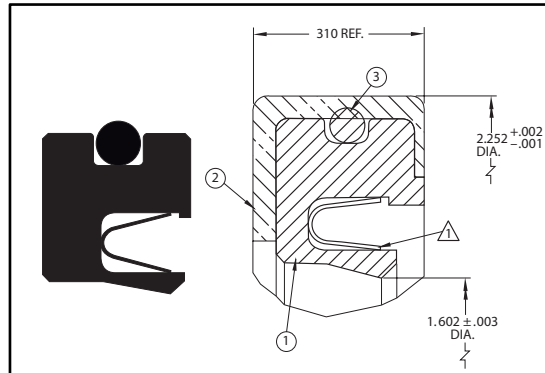

Chesterton EPS 115 Cantilever Spring-Energized Seal.

Results

Performance of seals was successfully validated in the equipment. The Chesterton 100 Series (115) Cantilever Spring-Energized Seal provided reliable sealing at high-speed while under vibration.

Where previous rubber lip seals lasted one year or less, the Chesterton seals have survived 5+ years – substantially increasing time between maintenance cycles.



Provides successful operation.