

PLAN 12

Discharge Recirculation with Strainer

- What** Discharge recirculation through a strainer and orifice to the seal.
- Why** To remove large solids from the Plan 11 recirculation.
- When** Not normally recommended because the strainer can clog and cause seal failure.

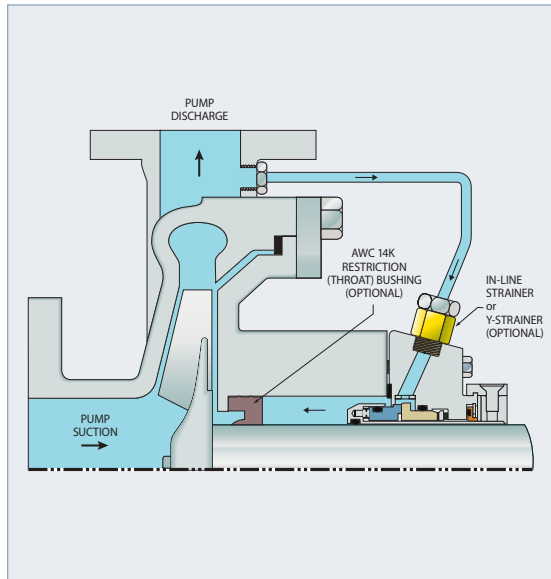

KEY

- 1 — From Pump Discharge
- 2 — Flush (F)
- 3 — Quench/Drain (Q/D)
- 4 — Seal Chamber

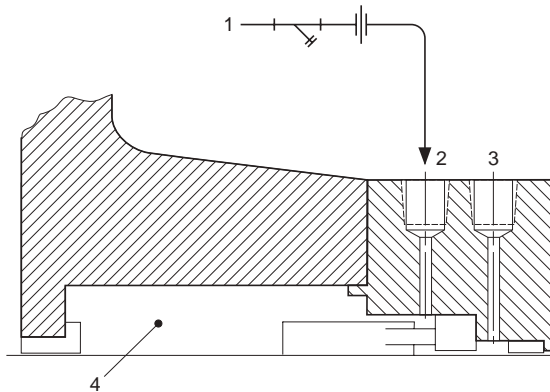
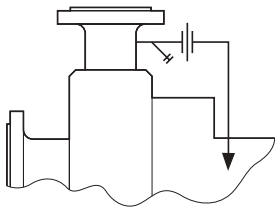

Drawing reproduced from ANSI/API Standard 682, Third Edition, September 2004, courtesy of the American Petroleum Institute.