

PLAN 32

Clean Flush

What Clean flush from an external source.

Why To cool and lubricate the seal faces; to provide clean fluid at the seal interface and prevent the buildup of solids in dirty process fluids.

When Used with a product with excessive solids, crystallizing product, or a product with a low vapor pressure.

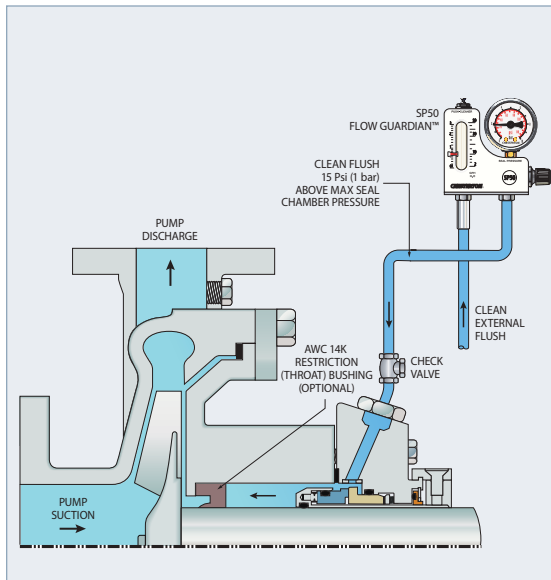

KEY

- 1 — From External Source
- 2 — Flush (F)
- 3 — Quench/Drain (Q/D)
- 4 — Seal Chamber

- FI—Flow Indicator
- PI—Pressure Indicator
- TI—Temperature Indicator

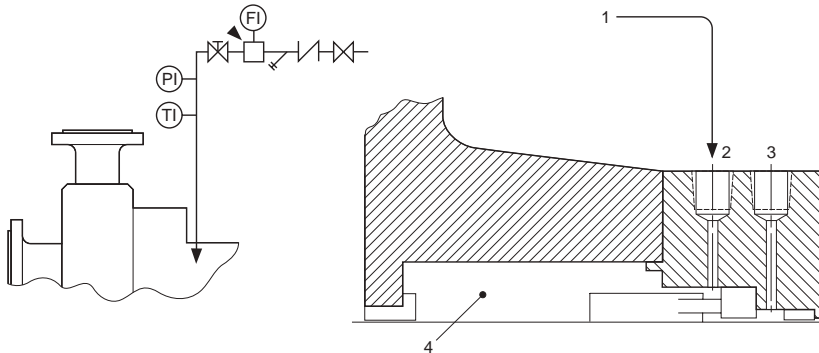

Drawing reproduced from ANSI/API Standard 682, Third Edition, September 2004, courtesy of the American Petroleum Institute.