

PLAN 55

Circulation External Buffer Fluid Source and Flow Guardian™ DP50

What Dual seal arrangement used with a dual flow meter measuring flow in and out of the seal.

Why To provide a buffer of clean fluid to lubricate the inboard and outboard seal faces.

When Used with products with high solids content.

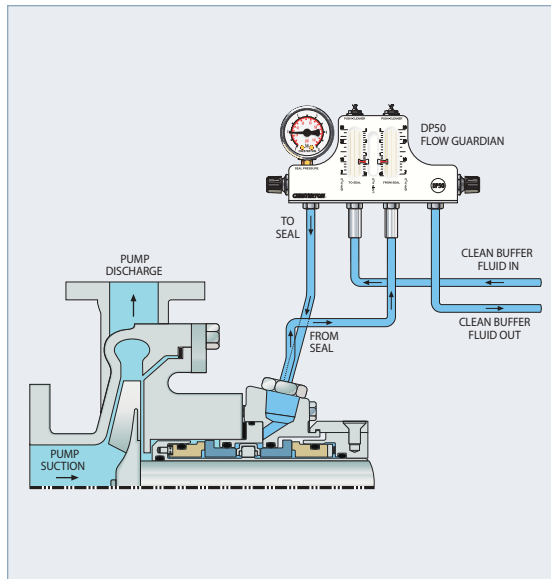

KEY

- 1 — From External Source
- 2 — To External Source
- 3 — Flush (F)
- 4 — Liquid Buffer Outlet (LBO)
- 5 — Liquid Buffer Inlet (LBI)
- 6 — Seal Chamber

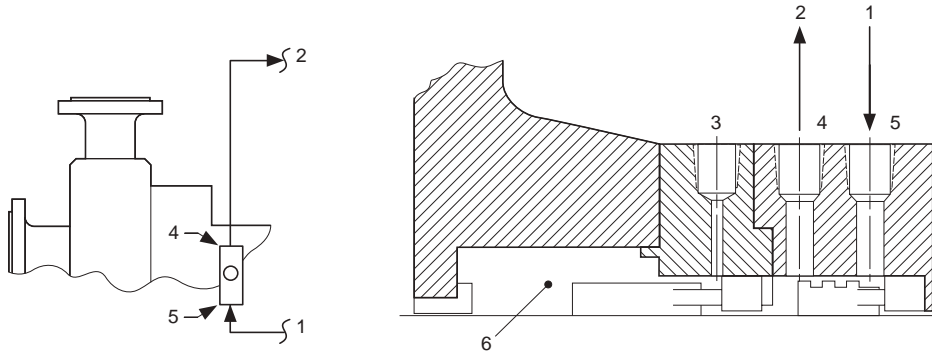

Drawing reproduced from ANSI/API Standard 682, Third Edition, September 2004, courtesy of the American Petroleum Institute.